

# INDU-COR™-G Module: 10-HFM-251-ICV

## Industrial Multitubular Ultrafiltration Module

### PRODUCT DESCRIPTION

<b>Part Number (KPN)</b>	0712501
<b>Membrane Chemistry:</b>	PVDF
<b>Membrane Type:</b>	HFM (neutral charge)
<b>Membrane Area:</b>	15.4 ft <sup>2</sup> (1.4 m <sup>2</sup> )
<b>Molecular Weight Cut-Off:</b>	100,000 Dalton (nominal)
<b>Construction:</b>	Seven (7) 1" diameter tubules in a PVC shell
<b>Face Plate:</b>	ABS
<b>Gasket:</b>	VITON®

### OPERATING AND DESIGN INFORMATION\*

<b>Maximum Inlet Pressure:</b>	90 psi @ 119 °F (6.2 bar @ 48 °C)
<b>Maximum Operating Temperature:</b>	122°F (50 °C) at 84 psi max
<b>Maximum Permeate Side Back Pressure:</b>	3 psi (0.2 bar)
<b>Minimum Outlet Pressure:</b>	5 psi (0.3 bar)
<b>Maximum Feed Side Pressure Drop:</b>	6.6 psi @ 119 °F (0.4 bar @ 48 °C)
<b>Allowable pH - Continuous Exposure:</b>	2.0 – 10.0 @ 119 °F (48°C)
<b>Allowable pH - Short Term Exposure:</b>	1.5 – 10.5 @ 119 °F (48°C)

\*Consult KSS Process Technology Group for specific applications.

### FEED FLOW VS. PRESSURE DROP\*

Circulation Flow		Crossflow Velocity		Pressure Drop	
gpm	(m <sup>3</sup> /hr)	f/s	m/s	psi	bar
133	30	7.8	2.4	2.0	0.14
210	48	12.3	3.7	4.3	0.29
266	60	15.5	4.7	6.0	0.41

\*Data based on water at 77° F and specific gravity of 1.0.

### NOMINAL DIMENSIONS

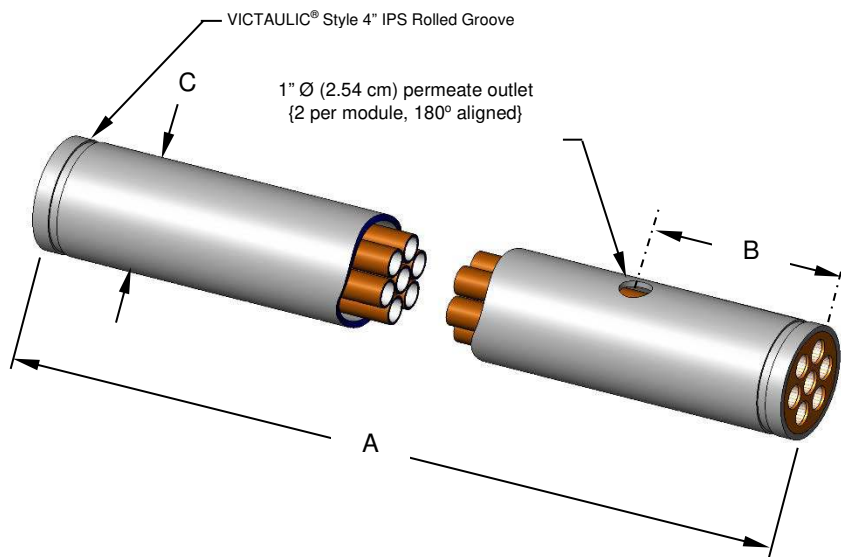

A		B		C	
inches	(mm)	inches	(mm)	inches	(mm)
110	(2794)	8	(203.2)	4 ½	(114.3)

OPERATING GUIDELINES

**Ancillary Parts**

KSS recommends that these membranes be used with KSS supplied ancillary parts. Sealing is provided by o-rings and gaskets. No additional sealing compound or tape is recommended for use on threaded connections.

**INDUCOR-G Module Process Pass Kits**

One Process Pass Kit contains;  
 Two Permeate Port Saddle Assemblies  
 Two 4" Coupling Assemblies

**Available in two styles of Permeate Port Saddle:**

1" IPS Socket Style Pass Kit      KPN 0211875  
 1" FNPT Threaded Style Pass Kit    KPN 0211885

**Permeate Port Saddle Assembly**

1" IPS Socket Style      KPN 0020616  
 1" FNPT Threaded Style    KPN 0020618

(Each assembly contains all the needed fastening hardware and one Viton® o-ring)

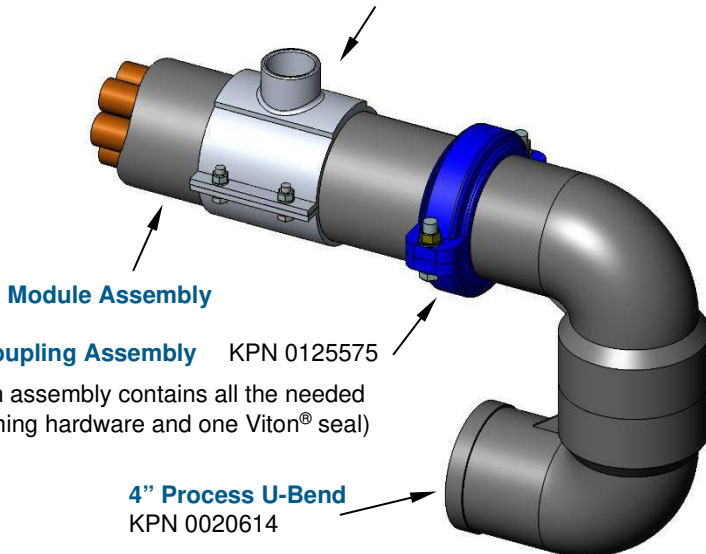
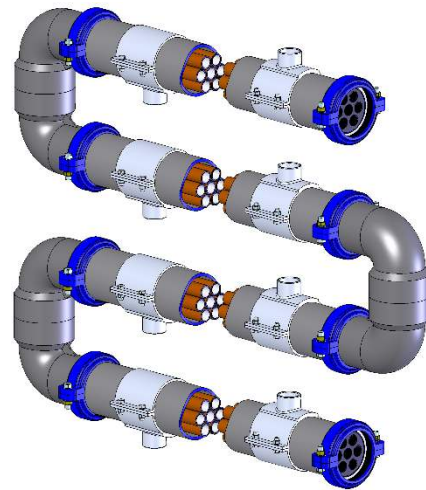

**4" Coupling Assembly**    KPN 0125575

(Each assembly contains all the needed fastening hardware and one Viton® seal)

**4" Process U-Bend**  
 KPN 0020614

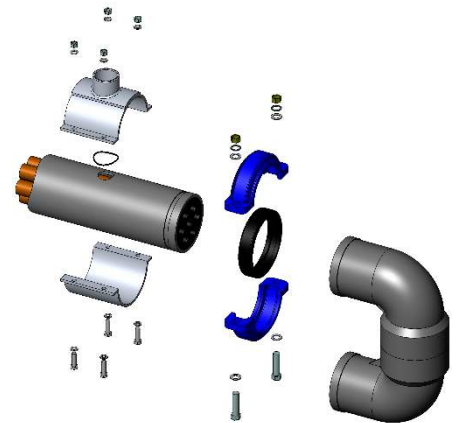

**Membrane Incompatibility**

Prior to exposing the membrane to any chemical, the chemical should be reviewed by Koch Separation Solutions. Aside from the listed chemicals below, synthetic coolants, semi-synthetic coolants, kerosenes, naphtha, gasoline, floc polymers may affect membrane performance.

**Chemicals that should be avoided include the following:**

- **Aprotic Solvent** (e.g., Dimethyl Formamide, Dimethyl Acetamide, N-Methyl Pyrolidine, etc.)
- **Chlorinated Solvents** (e.g., Methylene Chloride, Chloroform, Carbon Tetrachloride, etc.)
- **Ketones** (e.g., Acetone, Diacetone Alcohol, etc.)
- **Silicones** or Silicone based Defoamers (e.g., Siloxane)

*The information contained in this publication is believed to be accurate and reliable, but is not to be construed as implying any warranty or guarantee of performance. We assume no responsibility, obligation or liability for results obtained or damages incurred through the application of the information contained herein. Refer to Standard Terms and Conditions of Sale and Performance Warranty documentation for additional information*

**Koch Separation Solutions, Inc.** 850 Main Street, Wilmington, MA 01887  
 Main: +1-978-694-7000 • Fax: +1-978-657-5208 • Toll Free: +1-888-677-5624

For complete contact information and listing of our global locations, visit [www.kochseparation.com](http://www.kochseparation.com)

©2020 Koch Separation Solutions, Inc. All rights reserved worldwide. For related trademark information, visit [www.kochseparation.com/legal](http://www.kochseparation.com/legal).